



1.5 Megapixel CMOS USB 2.0 Camera

High Resolution CMOS Color Microscopy Camera specifically designed for the **Educational Market and Entry Level Microscopy Applications**

Outline

Lumenera has earned a reputation for excellence in the design and manufacture of high quality research grade microscopy cameras. Leveraging its expertise in optics, Lumenera has now launched a new product line specifically designed for the educational market as well as entry level microscopy applications.

INFINITY *lite* is a compact, affordable microscopy camera that delivers outstanding image quality and excellent value that no other manufacturer can match. Highlights include live video preview and real-time focus for the efficient capture of optimal images, an intuitive user application for camera control, full integration to popular third-party imaging applications through our TWAIN drivers, USB 2.0 interface, standard C-mount and compact design for trouble-free installation, and one standard cable for power and data to minimize clutter. As with all INFINITY cameras, no costly framegrabber is required.

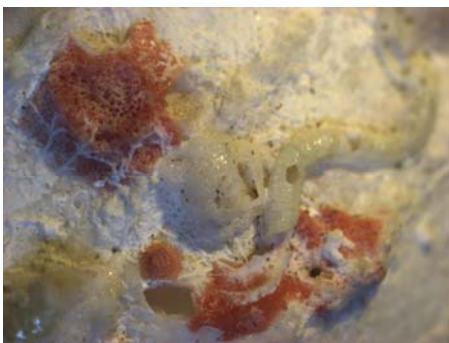

School districts can rest assured that purchasing an INFINITY *lite* camera today will place their students at the forefront of digital imaging technology. Whether students continue onto university, industry careers, or the research field, the imaging skills they acquire using an INFINITY *lite* camera can be directly applied to their professional work and research.

Performance/Features

- ❑ 1.5 megapixel camera
- ❑ High-speed USB 2.0 interface eliminates a framegrabber and facilitates ease of installation on both laptop and desktop computers
- ❑ INFINITY CAPTURE software application included
- ❑ Mac compatible
- ❑ On-board image processing of the INFINITY *lite*'s progressive scan 1.5 megapixel image sensor results in accurate color fidelity
- ❑ Full color sub-windowing allows for rapid, focus and scanning of samples: 15 fps at full 1440x1080 resolution and 60 fps at 640x480 resolution
- ❑ 8-bit pixel data
- ❑ Rugged dependability and versatility
- ❑ Camera control through an intuitive user TWAIN interface results in rapid image capture archiving and documentation for high throughput applications, demanding research environments and teaching facilities
- ❑ The INFINITY *lite* has a compact design equipped with a C-mount, facilitating installation on all microscope configurations including upright, inverted and stereo
- ❑ INFINITY *lite* cameras are software compatible with Windows™ 98 SE, Windows ME, Windows 2K, Windows XP, Windows Vista and Mac OS 10.4 operating systems
- ❑ Full one (1) year warranty

Specifications

INFINITY *lite*

Camera Sensor

Image Sensor	1/2.5" CMOS format, color, 6.0mmx4.5mm
Effective Pixels	1440x1080, 4.2µm square pixels
Frame Rate	15 fps at 1440x1080, 60 fps at 640x480
Dynamic Range	>60dB
Digital Output	8-bit uncompressed
Read Noise	20 e- rms

Camera Controls

Mass	245 grams
Power Requirement	USB bus power
Operating Temperature	0° C to +50° C
Operating Humidity	5%-95%, Non-condensing
Integration Time	1/1000 to 3 sec.
Shutter	Rolling shutter with single frame capture
ROI	User Selectable
Auto Exposure	Manual
White Balance	Manual
Gain	1 to 3X
Interface Connector	USB 2.0 high-speed interface
Dimensions (H)	Height - 1.91", Diameter - 2.60"
Lens Mount	C-Mount

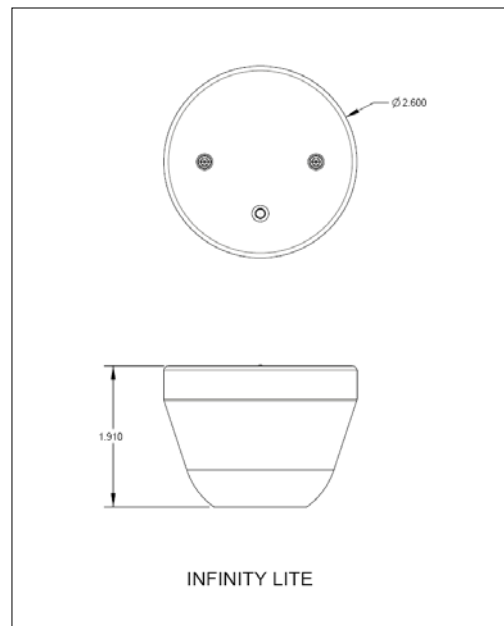

Recommended PC Specs:

- Pentium 4, 1.3 GHz or higher
- 512 Mb RAM
- 60 MB hard drive free space or more
- USB 2.0 Port
- Windows 2000, Windows XP, Windows Vista, Mac OS 10.4
- Quick Time V7

Minimum PC Specs:

- 600 MHz Processor
- 256 MB of SDRAM
- 20 MB hard drive free space
- USB 2.0 Port
- Windows 98 or ME

Product Includes:

- INFINITY *lite* digital camera for USB 2.0
- CD-ROM with INFINITY CAPTURE user application software
- TWAIN driver
- Documentation
- USB 2.0 cable

Ordering Information

INFINITY *lite* C – Color Camera

Dealer:

RNDr. Karel Martyčák – ML chemica
Zahradní 1a, CZ-664 41 Troubsko

tel.: 547 227 533 fax: 547 227 532
e-mail: info@mlchemica.cz

www.mikroskopý.net